

# KOMFORT EC S5B270 S14

## Heat and energy recovery air handling units

### Features

- Air handling units for efficient supply and exhaust ventilation in flats, houses, cottages and other buildings.

### Design

- The casing is made of expanded polypropylene (EPP) 9/16" - 1" thickness with high heat- and sound-insulating properties.

### Fans

- High-efficient external rotor EC motors and centrifugal impellers with backward curved blades are used for air supply and exhaust.
- EC motors have the best power consumption to air flow ratio and meet the latest demands concerning energy saving and high-efficient ventilation.

### Air filtration

- The supply and extract air streams are stripped of impurities on the panel MERV8 air filters. Optionally a MERV14 replaceable filter may be applied.

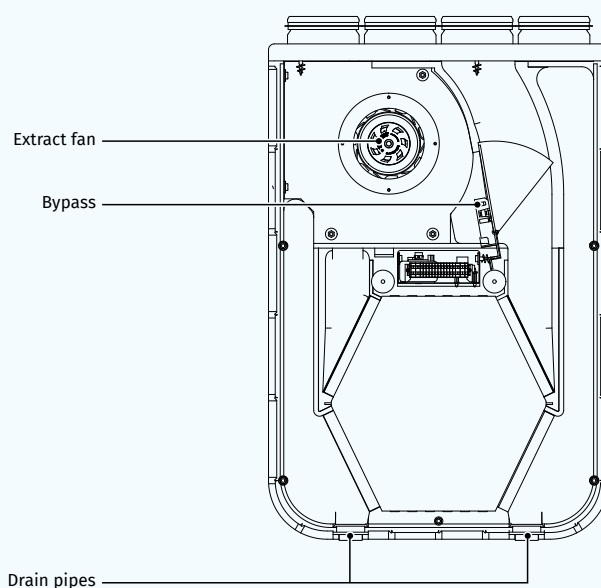
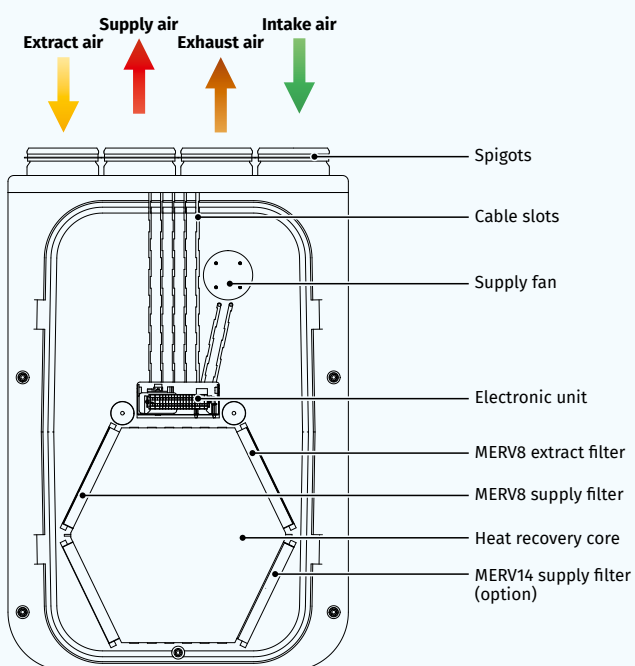

**Heat recovery**

- o **KOMFORT EC S5B270 S14** have a counter-flow polystyrene heat recovery core. In the cold season the extract air heat energy is absorbed by the cold intake air and the ventilation heat losses are minimized. The condensate produced by heat recovery is collected in a drain pan and drained to the sewage system. In the warm season the heat of the outside air is absorbed by the exhaust air. This way the supply air is pre-cooled and operation load for air conditioners is reduced.



**Control and automation**

- o **KOMFORT EC S5B270 S14** has an integrated control panel with sensor buttons and LED indication.

**Overall dimensions [in]**

Model	D	B	H	H1	L
<b>KOMFORT EC S5B270 S14</b>	4 15/16	23 1/4	33 9/16	35 3/16	12 7/16

**Bypass**

- o The **KOMFORT EC S5B270 S14** models are equipped with a bypass which can be opened if there is a need to cool down the ventilated area with cool intake air.

**Mounting**

- o The ventilation units are designed for wall mounting.
- o Due to universal casing design both left and right mounting is possible.
- o The unit and the filters are accessible for servicing through the front panel.
- o The service panel located on the left and on the right from the unit as seen from the supply air direction.

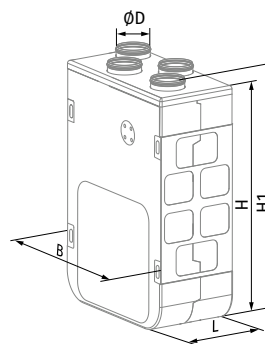

**Technical data**

Parameters	<b>KOMFORT EC S5B270 S14</b>
Voltage [V/50-60 Hz]	1~ 120
Power [W]	194
Current [A]	2.6
Maximum air flow [CFM]	177
RPM [min <sup>-1</sup> ]	3200
Sound pressure level at 10 ft [dBA]	34
Transported air temperature [°F]	-13...+122
Casing material	EPP
Insulation	9/16" - 1", EPP
Extract filter	MERV8
Supply filter	MERV8 (Option: MERV14)
Connected air duct diameter [in]	4 15/16
Weight [lb]	28.7
Heat recovery efficiency [%]	87-98
Heat recovery core type	counter-flow
Heat recovery core material	polystyrene
SEC class for S14 automation	A+
ErP	2016, 2018

MODEL	QUANTITY	COMMENTS	PROJECT
			location:
			architect:
			engineer:
			contractor:
			submitted by: