

## DESCRIPTION

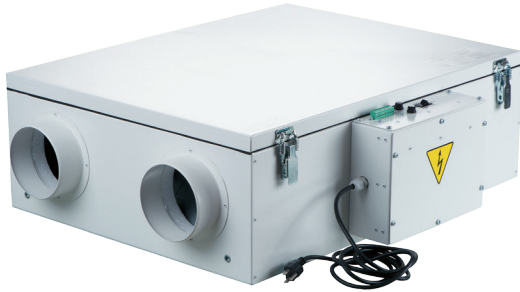

## HRV EC D 120 HEAT RECOVERY VENTILATOR

HRV EC D 120 are the complete whole house ventilation system designed to bring a continuous supply of fresh air into the house while exhausting an equal amount of stale air.

Five year warranty.

## CASING

Steel casing is covered with high-quality multilayer aluminium and zinc alloy to prevent corrosion. The casing is equipped with a switch to turn the ventilator off when the service panel is opened.

## FILTER

Washable MERV 6 air filters in exhaust and supply air streams. Optional supply: anti grease aluminum filter.

## FANS

High efficient electronically commutated motors with external motor and impeller with forward curved blades. EC motors are featured with high performance and total speed controllable range. The electric motors and impellers are dynamically balanced.

## HEAT RECOVERY CORE

Polystyrene core ensures efficient heat recovery.



## DEFROST SYSTEM

To protect the Heat Recovery Core, an antifreeze electronic protection system is applied. It switches the supply fan off according to the temperature sensor settings. Warm extract air defrosts the HRV core then the supply fan switches on and the ventilator continues operating under rated conditions.

## SUITABLE FOR:

Bathroom / kitchen / apartments / cottages / small offices.

## CONSTANT FLOW

HRV EC D 120 CF has an automatic constant air flow control function to keep the air flow in supply and exhaust air ducts constant even in case of variable air resistance.

This function is provided with the integrated air flow control units. The electronic sensors convert the actual air flow to the analogue signal that is proportional to the air flow in the air duct. These signals are transmitted to the controller that controls the rotation speed of a respective fan in such a way that the actual rotations speed is equal to the set value.

## MANUAL BALANCING

Manual balancing is a standard balancing system. Fan speed manually adjusted by operating on units controller (built-in control board with independent fan speed adjustment 0 %-100 %).

## CONTROL BOARD

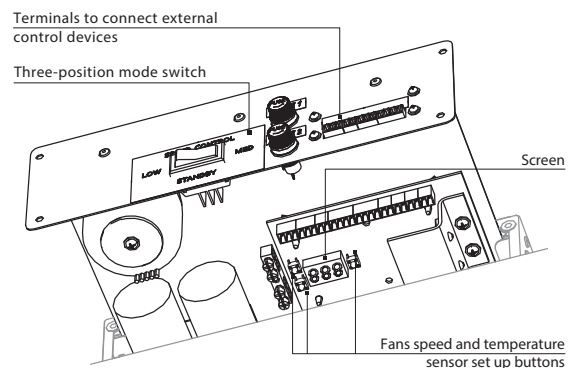

The unit incorporates an integrated control system with following functions:

- Operation mode switch.
- Airflow balancing enabled by supply and exhaust fan independent speed adjustment from 0 to 100 % (percentage is displayed on built-in screen).
- Automatic recovery core frost protection.
- External control device connection (up to 5 at the same time).

## PERFORMANCE

External Static Pressure		Net Supply Air Flow		Gross Air Flow				Power
				Supply		Exhaust		
Pa	in. W.G.	L/s	CFM	L/s	CFM	L/s	CFM	Watts
25	0.1	89	189	92	195	83	175	204
50	0.2	87	185	90	190	81	171	201
75	0.3	85	180	88	185	79	167	200
100	0.4	82	175	85	180	78	164	198
125	0.5	80	169	82	175	76	161	196
150	0.6	78	165	80	170	75	159	194
175	0.7	76	160	78	165	74	157	193
200	0.8	74	156	76	161	73	154	190
225	0.9	68	144	74	156	70	149	188
250	1	66	140	71	151	68	144	186
275	1.1	64	135	69	145	66	139	183
300	1.2	61	128	66	140	63	132	180
325	1.3	57	121	63	134	59	125	176
350	1.4	52	110	60	127	54	114	176
375	1.5	43	91	55	117	44	94	164
400	1.6	30	64	44	92	31	67	151
425	1.7	17	35	18	37	17	36	132
450	1.8	8	16	7	14	8	16	128

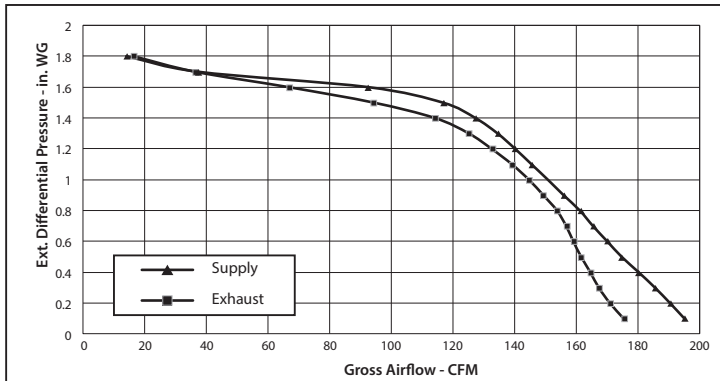

SOUND  
1.9 Sones (30 L/s @ 50 Pa)

MODE	SUPPLY TEMPERATURE		NET AIR FLOW		AVERAGE POWER	SENSIBLE RECOVERY EFFICIENCY	APPARENT SENSIBLE EFFECTIVENESS	NET MOISTURE TRANSFER
	°C	°F	L/s	CFM	(Watts)	SRE (%)	ASEF (%)	
HEATING	0	32	30	64	86	60	70	0.5
	0	32	45	95	114	57	67	0.4
	0	32	50	106	126	55	65	0.4
COOLING	35	95	30	64	86	29	61	0.04

Model	Volts	Max. Watts	Max. Amps
HRV EC D 120	120V, 60Hz	204	2.5

DIMENSIONS

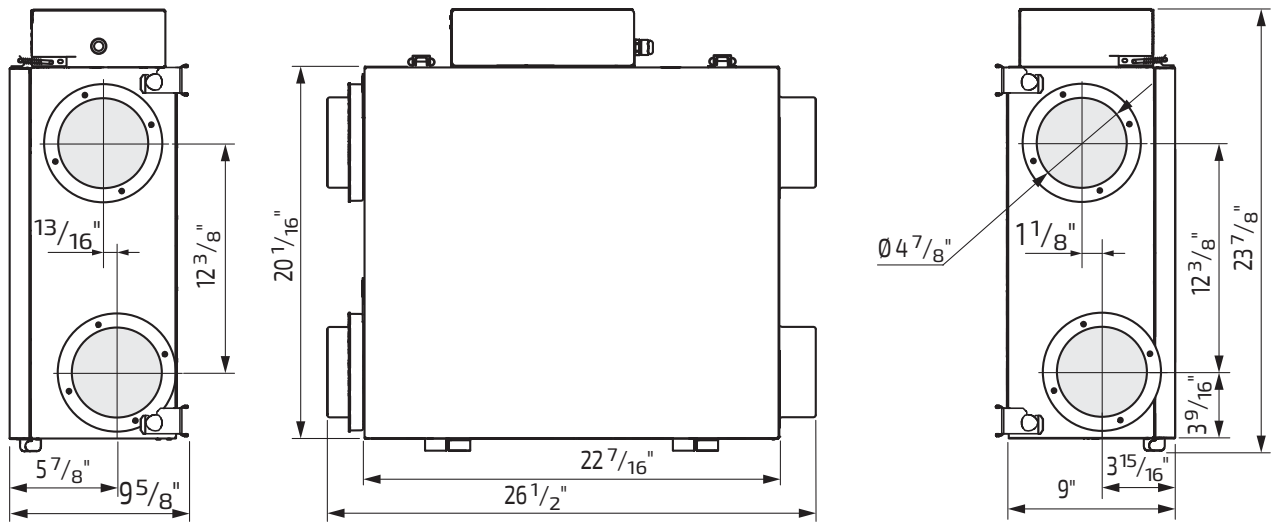

MODEL	QUANTITY	COMMENTS	PROJECT
			location:
			architect:
			engineer:
			contractor:
			submitted by:

