

CEILEO 110 LIGHT

CEILING BATH FAN



Description

- The Ceileo fans are centrifugal exhaust fans for ceiling mounting in bathrooms and other utility spaces.
- The Ceileo fans are designed for long duct runs. The fans are compatible with 4" and 6" air ducts.

Benefits

- Low noise level
- Reliable asynchronous double-speed motor
- Energy-efficient LED light
- Adjustable mounting brackets
- Ready for plug-in humidity or motion sensing module (modules are sold separately)

Specification

- Voltage: 120 V, 60 Hz
- Motor: AC motor
- Power consumption: 16 - 27 W
- Sones: 0.3 - 0.7
- Airflow capacity: up to 125 CFM
- Duct compatibility: Ø 4" and 6"
- IPX4 protection
- Five-year warranty

Performance

SEC CLASS	Duct Dia	Speed	Energy Star qualified	Watts*	Amps*	RPM*	Sones*	CFM vs. Static Pressure in.W.G.						Max. Ps	Volts/Hz	
								0"	0.1"	0.2"	0.25"	0.3"	0.4"			0.5"
C	4"/6"	HS	V	27	0.23	1000	0.7	125	112	100	92	83	57	31	0.58	120/60
		LS		16	0.17	800	0.3	78	64	45	35	26	-	-		

* Indicated at 0.1 in.W.G.

Overall dimensions [in]

Model	D	d	L1	L2	A	B	C	E	H	h	a	b
Ceileo 110 Light	5 ⁵³ / ₆₄	3 ⁵⁵ / ₆₄	3 ¹⁵ / ₁₆	1 ⁴⁹ / ₆₄	12 ⁶³ / ₆₄	10 ⁵ / ₃₂	10 ¹⁵ / ₆₄	15 ³⁵ / ₆₄	7 ¹³ / ₃₂	2 ⁷ / ₁₆	8 ³ / ₁₆	4 ²⁷ / ₃₂

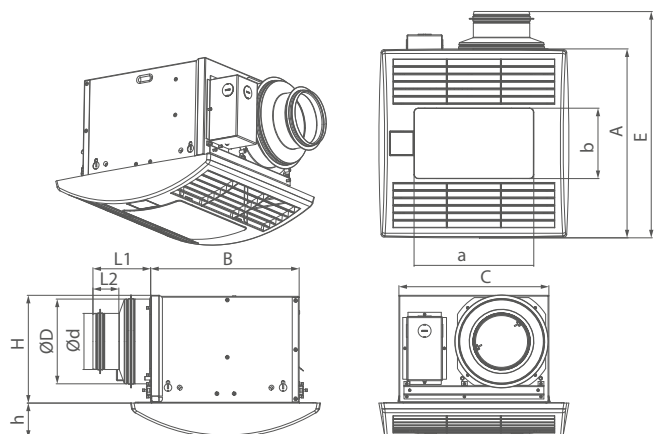

MODEL	QUANTITY	COMMENTS	PROJECT
			location:
			architect:
			engineer:
			contractor:
			submitted by: